

LED Driver Surge Protection PLUS II

Surge Protection With Gas Discharge Tube Technology for Protection of LED Drivers and Controls



ABLE POWER PRODUCTS

**HIGHWAY & STREET LIGHTING | PARKING LOTS & PATHWAYS | BUS & TRAIN DEPOT LIGHTING
DIGITAL SIGNS | PARKING GARAGES & TUNNELS**

GDT / TMOV hybrid circuit eliminates leakage and follow on current extending the life of the surge protector.

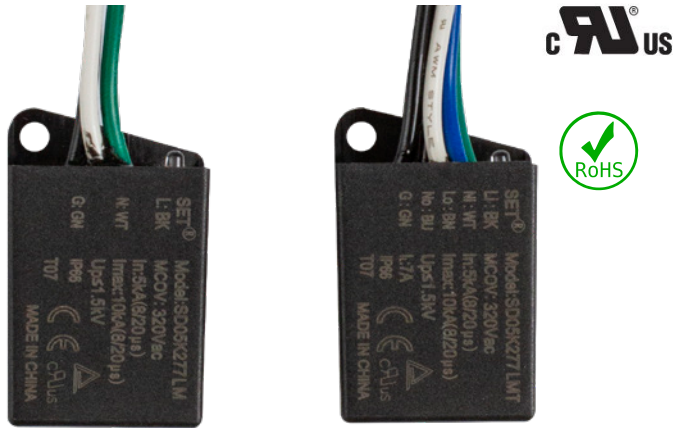

Features

- Small, Compact Footprint
- Series or Parallel Connection
- L-N, L-G, N-G Protection
- Safety Thermal Fusing
- Diagnostic Light
- Mounting Tab
- 10-Year Product Warranty
- Lifetime Warranty for GDT* Models
- IP 66 Rated

Wiring Diagram

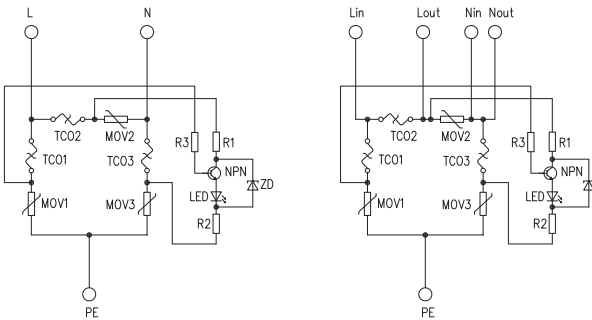

Dimensional Drawing (in)

L	1.75
L ₁	6.00
W	1.22
H	0.87
d	0.17
d ₁	0.12
B	1.56
B ₁	1.02
B ₂	0.18
B ₃	0.06

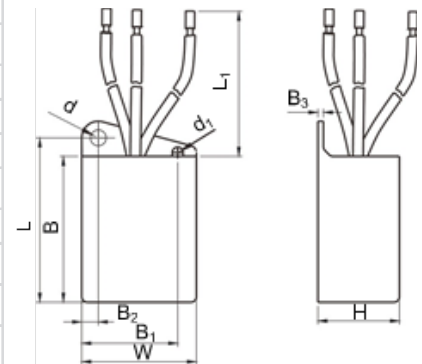

Product Model	Operating Voltage	I _n	I _{MAX}	U _{oc}	MCOV	Clamp Voltage	Thermal Fusing	3-Mode Protection	Gas Discharge Tube	Green Diagnostic Light	Mounting Tab	Operating Temperature	Wiring Configuration
AP5P277G	120V-277V	5kA	10kA	10kV	320V	1300V	•	•	•	•	•	-40°C to +70°C	Parallel
AP5S277G	120V-277V	5kA	10kA	10kV	320V	1300V	•	•	•	•	•	-40°C to +70°C	Series
AP5P277L	120V-277V	5kA	10kA	10kV	320V	1200V	•	•	•	•	•	-40°C to +70°C	Parallel
AP5S277L	120V-277V	5kA	10kA	10kV	320V	1200V	•	•	•	•	•	-40°C to +70°C	Series